

SCIENCE

(Physics)

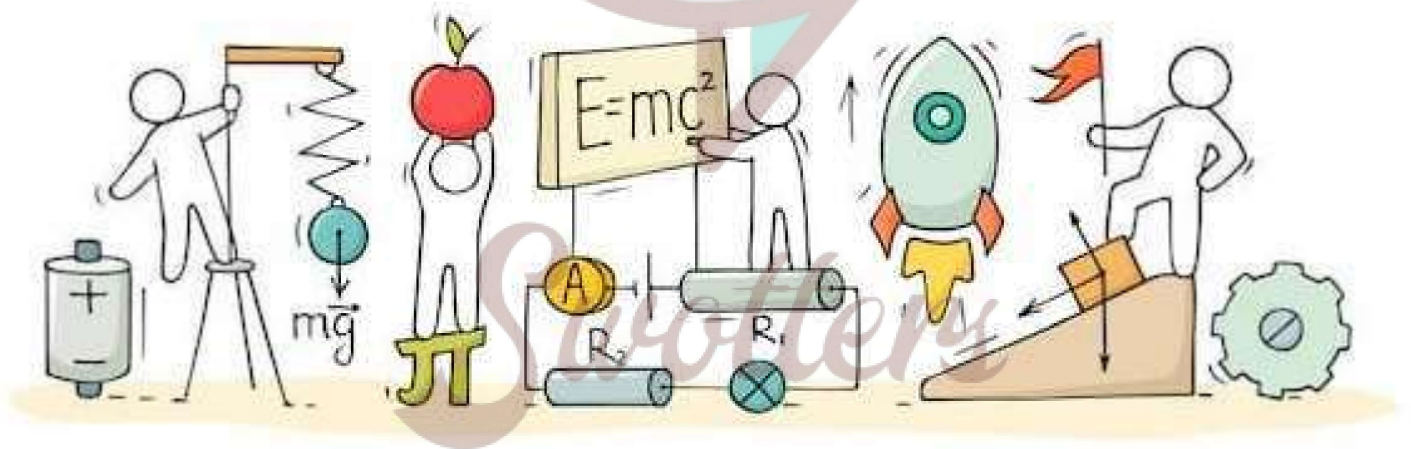

Important Questions

➤ Multiple Choice Questions:

1. Biogas is formed in the
 - (a) presence of air only
 - (b) presence of water only
 - (c) absence of air only
 - (d) presence of water and absence of air
2. Biogas is a better fuel than animal dung cake because
 - (a) biogas has lower calorific value.
 - (b) animal dung cake has high calorific value
 - (c) biogas burns smoke and leaves no residue
 - (d) biogas is used as a fuel for cooking only whereas dung cake can be used for cooking, illuminating the lanterns.
3. Most of the sources of energy we use represent stored solar energy. Which of the following is not ultimately derived from the Sun's energy?
 - (a) geothermal energy
 - (b) wind energy
 - (c) nuclear energy
 - (d) biomass
4. The working fluid in ocean thermal power plant is:
 - (a) Volatile liquid like ammonia
 - (b) petrol
 - (c) charcoal
 - (d) liquified petroleum gas
5. Ocean thermal energy is produced due to
 - (a) pressure difference at different levels in the ocean.
 - (b) temperature difference at different levels in the ocean.
 - (c) energy stored by waves in the ocean.
 - (d) tides rising out of the ocean.
6. A device in which electricity is produced by the process of controlled nuclear fission reaction is called

- (a) nuclear chain reaction
- (b) hydel power plant
- (c) nuclear reactor
- (d) thermal power plant

7. India exploded her first underground nuclear device at

- (a) Ranchi
- (b) Kota
- (c) Jaipur
- (d) Pokhran

8. Fusion reaction is also known as

- (a) chemical reaction
- (b) elastic scattering
- (c) thermonuclear reaction
- (d) photo nuclear reaction

9. A good fuel should possess

- (a) high ignition temperature
- (b) moderate ignition temperature
- (c) high calorific value
- (d) both high calorific value and moderate ignition temperature

10. Geothermal energy is:

- (a) Heat energy in the interior of earth
- (b) energy of molten mass exists in the form of magma inside the earth.
- (c) molten lava on the surface of earth
- (d) energy obtained from solar thermal electric plants

➤ **Very Short Question:**

1. What is meant by non-renewable sources of energy?
2. Name two non-renewable or conventional sources of energy.
3. What is a fossil fuel?
4. Give two examples of fossil fuels.
5. How is the increase in demand for energy affecting our environment adversely?

6. What does "LPG" stands for?
7. Write the name of the main constituent of "LPG".
8. What does "CNG stand for?
9. Write the name of the main constituent of "CNG".
10. Name the device/ technique to produce electricity by burning fossil fuels.

➤ Short Questions:

1. Mention any three qualities of an ideal source of energy.
2. Would your choice regarding choice regarding a fuel for cooking food be different if you lived
 - (a) in a forest,
 - (b) in a remote mountain or small island,
 - (c) in New Delhi and
 - (d) five centuries ago? If yes, name the type of fuel used in different cases.
3. Why are fossil fuels known as a non-renewable source of energy?

Or

State the reason for calling fossil fuels as non-renewable source of energy.

4. Why are many thermal power plants set up near coal or oil fields?
5. What steps can be taken to minimize environmental pollution caused by the burning of fossil fuels?
6. What are fossil fuels? "Burning of fossil fuels leads to acid rain", Justify this statement.
7. List three energy sources that are considered to be inexhaustible. State three reasons in support your answer.
8. Explain how burning of fossil fuels cause acid rain.

➤ Long Questions:

1. Describe the construction of a box type solar cooker or show it with the help of a diagram. How is the rise in temperature obtained in this set up? Mention two advantages and two limitations of solar cookers.
2. What are
 - (i) Solar concentrators and
 - (ii) Solar cell panels? How are they improvement on simple devices? Why is it that solar panels are costly?
3. Name any three forms of energy of the oceans which can be converted into usable energy

forms. Describe how it is done in each case. What is the likelihood of their use on a large scale?

➤ Assertion Reason Questions:

1. Following questions consist of two statements – Assertion (A) and Reason (R). Answer these questions selecting the appropriate option given below:

- (a) Both A and R are true, and R is the correct explanation of A.
- (b) Both A and R are true, but R is not the correct explanation of A.
- (c) A is true but R is false.
- (d) A is false but R is true.

Assertion(A): Nuclear fusion is used to generate electricity.

Reason (R): Nuclear power is used because it cannot be controlled.

2. Following questions consist of two statements – Assertion (A) and Reason (R). Answer these questions selecting the appropriate option given below:

- (a) Both A and R are true, and R is the correct explanation of A.
- (b) Both A and R are true, but R is not the correct explanation of A.
- (c) A is true but R is false.
- (d) A is false but R is true.

Assertion(A): Charcoal is a better fuel than wood for domestic purposes.

Reason (R): Charcoal burns without flames and does not produce smoke during burning.

✓ Answer Key-

➤ Multiple Choice Answers:

- 1. (d) presence of water and absence of air
- 2. (c) biogas burns smoke and leaves no residue
- 3. (c) nuclear energy
- 4. (a) Volatile liquid like ammonia
- 5. (b) temperature difference at different levels in the ocean.
- 6. (c) nuclear reactor
- 7. (d) Pokhran
- 8. (c) thermonuclear reaction
- 9. (d) both high calorific value and moderate ignition temperature
- 10. (c) molten lava on the surface of earth

➤ Very Short Answers:

1. Answer: The sources of energy which have been formed in nature long ago under certain

conditions of temperature and pressure. For example, fossil fuels like coal and petroleum.

2. Answer:

Coal,

Petroleum.

3. Answer: The combustible substance formed from the dead remains of the animals and plants which were buried deep under the surface of the earth over millions of years is called fossil fuel.

4. Answer: Coal and petroleum.

5. Answer: More use of fossil fuels for fulfilling the increasing demand for energy is polluting the air, which is a great health hazard.

6. Answer: LPG stands for "Liquid Petroleum Gas".

7. Answer: The main constituent of "LPG" is butane.

8. Answer: CNG stands for "compressed Natural Gas".

9. Answer: The main constituent of CNG is methane.

10. Answer: Thermal power plant produces electricity by burning fossil fuels.

➤ Short Answer:

1. Answer: A good source of energy should have the following characteristics. It should supply enough amount of useful energy.

be easily stored.

be easily transported.

2. Answer:

Yes.

(a) wood would be used for cooking food in a forest.

(b) Wind energy from a wind mill or energy of flowing water would be used for cooking food in a remote mountain or small island.

(c) LPG would be used for cooking food in New Delhi.

(d) Wood and cakes of cow dung were used for cooking food five centuries ago.

3. Answer: Fossil fuels like coal, petroleum and natural gases take millions of years for their formation. If these fuels are exhausted today, then they will not be formed very soon. Hence, they are known as non-renewable sources of energy.

4. Answer: In a thermal power plants, fuel like coal or oil is used in large quantity to produce electricity. These plants are usually set up near coal or oil fields so that the fuel is easily available and the problem of air pollution while transporting the fuel may be minimized.

5. Answer: We can minimize environmental pollution caused by the burning of fossil fuel by growing more and more trees,
Using smokeless chulahs and
smokeless chimneys in thermal power plants.
6. Answer: For fossil fuels: The combustible substance formed from the dead remains of the animals and plants which were buried deep under the surface of the earth over millions of years is called fossil fuel.

Gases produced due to the burning of fossil fuels react with water vapours in air to produce acids like carbonic acid, sulphuric acid and nitric acid. These acids come down to earth with rain known as acid rain.

7. Answer:

Coal,

Petroleum

Natural gas.

These are inexhaustible energy' source because

their deposit under earth is limited,

their continuous use will ultimate consume them and

they are formed in very long period of time.

8. Answer: Gases produced due to burning of fossil fuels give rise to acids after reacting with water vapours in air. For example.

$\text{CO}_2 + \text{Water} \rightarrow \text{Carbonic acid}$

$\text{SO}_2 + \text{Water} \rightarrow \text{Sulphuric acid}$

$\text{NO}_2 + \text{Water} \rightarrow \text{Nitric acid}$

➤ Long Answer:

1. Answer:

Solar Cooker (Box Type)

Construction:

It consists of a wooden box (rectangular in shape) in which a metallic box painted black is fitted. The space between wooden box and metallic box is filled with an insulating material like thermocol. The insulating material minimizes the heat lose by conduction and radiation.

The metallic box is covered by a thick glass sheet. A plane mirror reflector is used to reflect the sun rays and attached to the box (Figure 7).

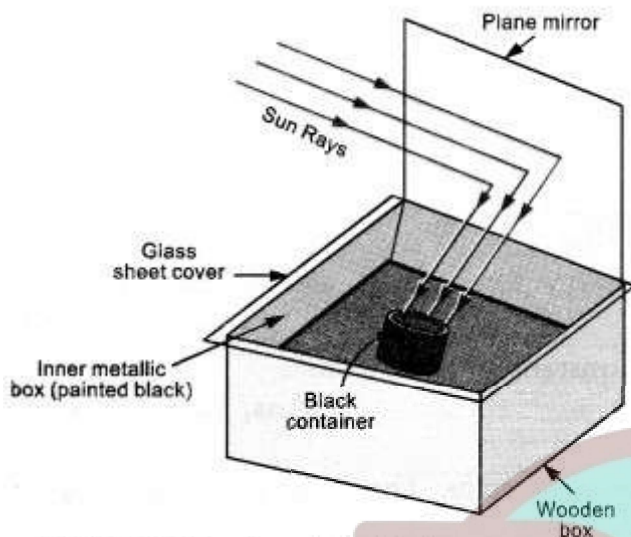

FIGURE 7. Box type Solar Cooker

The un-cooked food placed in the black container is put inside the box.

Working:

The plane mirror reflector is adjusted in such a way that maximum sun light falls on it. The light reflected by the plane mirror falls on the thick glass sheet cover.

The heat radiation (i.e. infra-red rays coming from the sun have short wavelength and high energy) pass through the glass sheet and are absorbed by the black container or any other object placed in the box and black surface of the box. The heat radiation entered in the box are not able to come out of the box through the glass sheet. Thus, the heat radiation are trapped in the box and the inner part of the box becomes hot. The effect is known as green house effect. (For the detail of green house effect, Refer Additional Topic at the end of this chapter). The temperature inside the box increases from 100°C to 140°C . Thus, the food in the container is cooked.

Advantages of Box type Solar cooker:

Economical: The cost of cooking food in the solar cooker is very small as money is only spent to purchase the solar cooker.

Pollution: No pollution is caused as there is no burning of fuel.

Disadvantages of Solar cooker:

Food cannot be cooked at night.

Food cannot be cooked on a cloudy day.

Food cannot be cooked quickly as solar cooker takes 4 to 5 hours to cook it.

2. Answer:

(i) Solar concentrators:

Solar concentrators are the devices used to concentrate the solar energy over a small area.

When a parallel beam of sunlight falls on a polished concave surface (like concave mirror), then the beam of sunlight concentrates at the focus (F) of the concave surface after reflection (Figure 8).

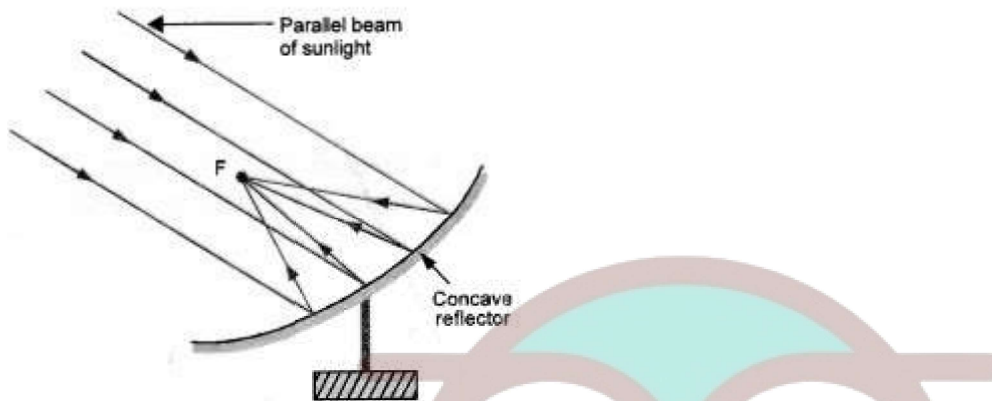

FIGURE 8. Solar Concentrator

As a result of this concentrated beam of sunlight, the temperature at point F increases considerably. If we place a piece of paper at F, then it begins to burn after some time. A concave spherical surface which concentrates the beam of sunlight at a point is called solar concentrator.

(ii) Solar cell panels:

A group of solar cells connected to each other in a certain pattern forms a solar panel (Figure 10).

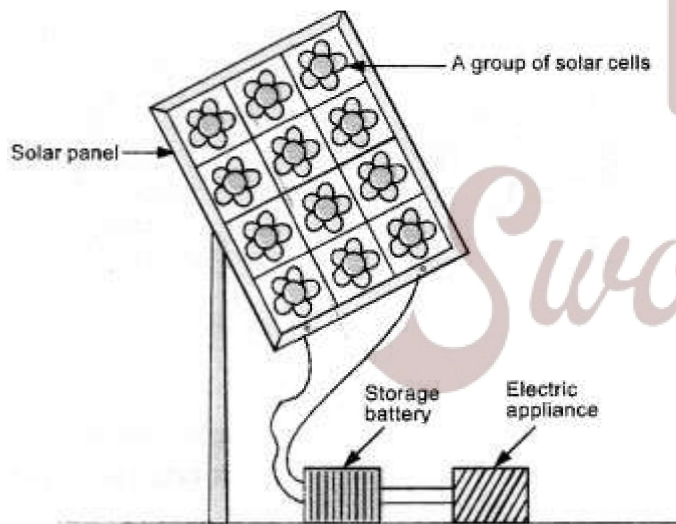
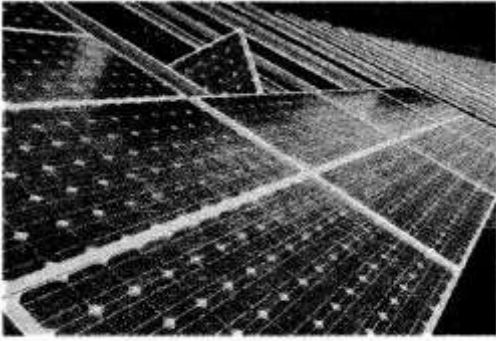

FIGURE 10

A solar panel converts sunlight into electrical energy. The efficiency of solar panel is very large as compared to the efficiency of a solar cell.



SOLAR PANELS

During day time, sunlight falling on the solar panel is converted into electrical energy which is stored in a battery connected to it. As soon as sunlight stops falling on it (during night and cloudy day), the battery begins to supply electric current to the appliances like electric bulbs and electric tubes connected to it.

Solar panels have limited uses. They can not be used to meet our domestic needs of electricity.

This is because of the following reasons:

The solar cells used in a solar panel are made of pure silicon. The production of pure silicon is very costly affair. These solar cells in a solar panel are joined to each other with a best conductor silver to reduce the resistance of the solar panel to get maximum electricity.

But silver metal is also costly. Thus, we find that the cost of fabricating a solar panel is very high.

The storage battery connected to a solar panel can supply direct current (D.C.). So only those electric appliances can operate with the solar panel which require direct current. However, the electric appliances which require alternating current (A.C.) cannot be operated with the solar panel.

Solar panel can supply the electricity continuously only if the sun shines during day time.

3. Answer:

The energy from sea or ocean water is available in the following forms :

- Energy of sea waves
- Tidal energy
- Ocean thermal energy

Energy of sea waves:

High winds blow across the sea. These winds produce high waves on the surface of water in the sea or ocean. Thus, the water in the sea moves as water waves'. The kinetic energy of this moving water rotates the turbine of a generator. Hence, electricity is produced.

Limitation of Energy of Sea waves: Energy of sea waves can be used only if strong winds

blow all the times across the sea and there are high water waves in the sea. However, as soon as strong winds stop to blow, the electric generator stops producing electricity. Hence, we cannot depend much on the energy of sea waves.



ENERGY OF SEA WAVES

Tidal energy:

The alternate rise and fall of water of the ocean twice in nearly 24 hours is known as tide. The tides are caused due to the gravitational force of attraction exerted by the moon and to some extent by the sun on the water of the ocean. At the time of new and full moon, when the sun and the moon are in a straight line, tides are very high. When the sun and the moon are at right angle from the earth, tides are low. The kinetic energy of water waves during tides is used to produce electricity.

Tidal power plants are constructed near narrow Bays (Figure 11).

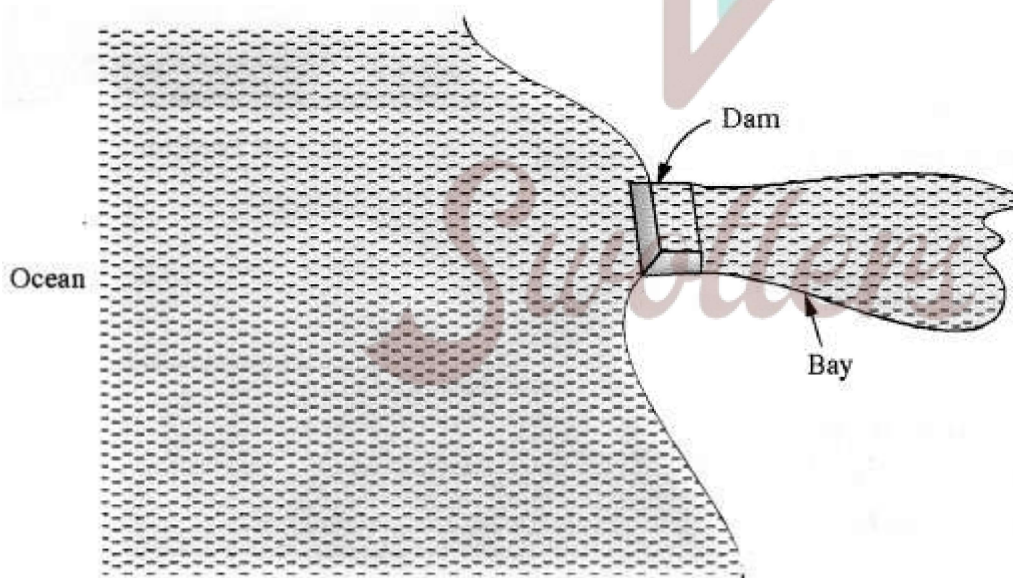

FIGURE 11

During tides, the gates of the dam are opened. The rising water is allowed to fall on the turbine of the generator which produces electricity.

Thus, kinetic energy of the water is converted into electrical energy. During low tides, gates of the dam are closed and hence the water level behind the dam rises. This raised water has

potential energy. Again the gates are opened and the water is allowed to fall back into the bay. This falling water is used to rotate the turbine of the generator. Hence the electricity is produced continuously.

Ocean thermal energy:

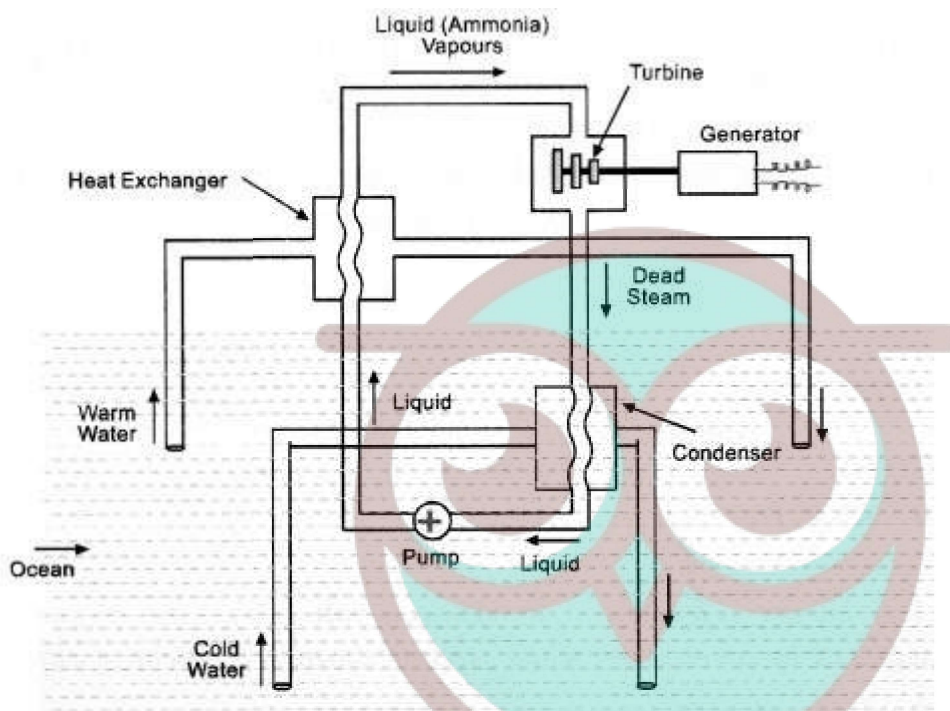

FIGURE 12 OTEC Power Plant

For operating OTEC power plant, temperature difference of 20°C or more between the surface water of ocean and water deep into the ocean is required. The warm surface water of ocean is used to boil liquid like ammonia or chlorofluorocarbon carbon (CFC). The vapours of this liquid at high pressure are used to rotate the turbine of the generator to produce electricity. The unused vapours (known as dead steam) are again converted into liquid by the cold water pumped up from the deep ocean. This process is repeated time and again to convert ocean thermal energy into electric energy (i.e., electricity). The main advantage of OTEC power plant is that it can be operated for 24 hours in a day throughout the year.

➤ Assertion Reason Answer:

1. (c) A is true but R is false.
2. (a) Both A and R are true, and R is the correct explanation of A.